



Step by Step Instructions

Cantivex Assembly

Shelf components for the wall mounted and modular Cantivex system.

1. Top Pendant Rail



2. Bottom Fender Rail
2A. Rubber Extrusion



3. Wall Strip 615mmL / 1515mmL
3A. Fender Rail Release Clip

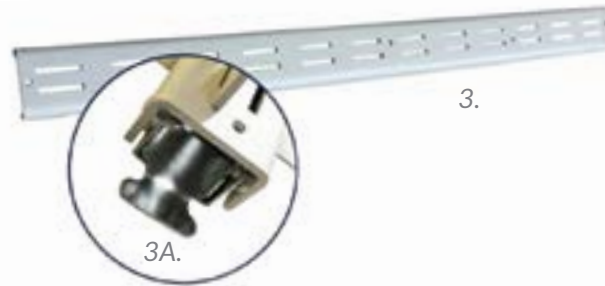

4. Rear Shelf Rail



5. Front Shelf Rail



6. Shelf Bracket | 300, 450 & 600mm Long

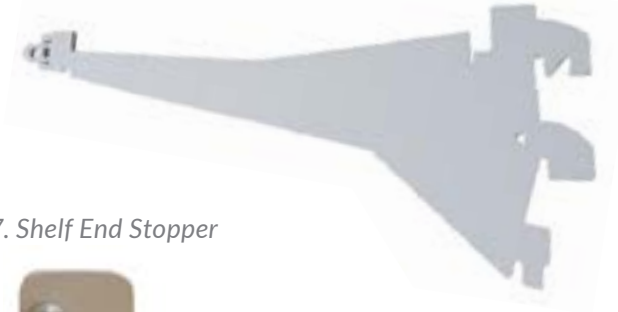

7. Shelf End Stopper



8. Shelf End Upstand | 300, 450 & 600 mm Long



9. Front & Rear Shelf Joiners.

(Only required if extending shelving unit)



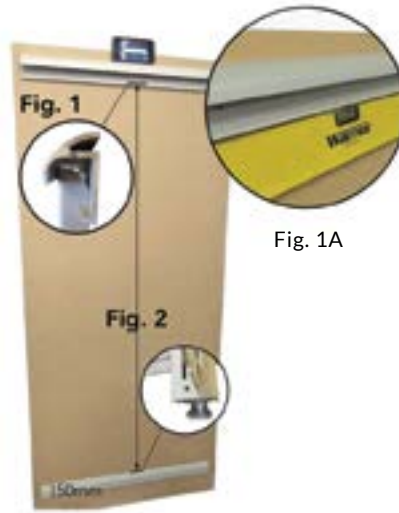

Step 1 | Take Top pendant rail. (Fig. 1) and mount level along wall using wood screw provided. Screw back to wall internal strips. (Fig. 1A)

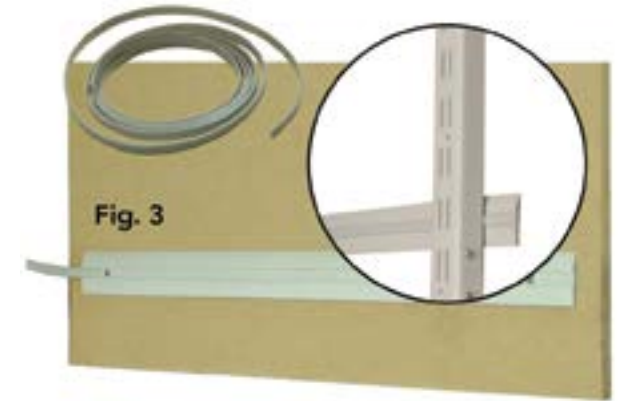

Step 3 | Insert P.V.C rubber extrusion into bottom fender rail, (using a little liquid soap to help it slide through extrusion). (Fig. 3)

MEASUREMENTS

Vertical Wall Strip Length	Distance Between Top & Bottom Rails
615mm	467 Strip
1515mm	1367 Strip

Distance required between bottom of Pendant Rail and top of Fender Rail is calculated as 148mm less than wall strip length. i.e. 1515mm length strip less 148mm = 1367mm

Step 2 | Take bottom Fender Rail and mount on wall. **IMPORTANT**, must be as instructions and be exact distance as show so Fender Bracket will clip into place. Top to bottom, Pendant Rail & Fender Rail must be parallel to each other.



Step 4 | Insert vertical wall strips in desired distance apart. Inserting into top pendant rail, Take care not to damage powder coating when inserting into top rail. (Fig. 4)



Fig. 5



Fig. 5A



Fig. 5B

Step 5 | Hang vertical wall strip down vertical. (Fig. 5) so it sits flat against bottom fender rail. Locate Fender Rail Clip under bottom of rail and close. (Fig. 5A & 5B)

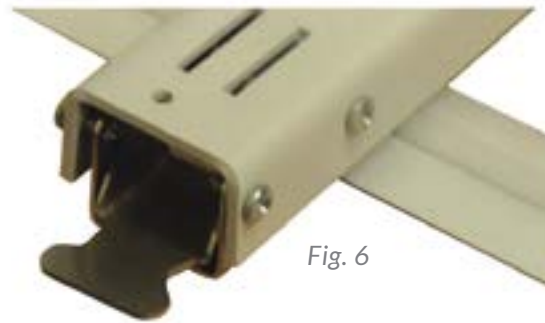

Fig. 6

Step 6 | Clip in fender bracket into groove under bottom fender channel and clip firmly back into place. (Fig. 6)



Fig. 7

Fig. 7A

Step 7 | Mount shelf brackets at desired height on vertical wall strips. (Fig. 7 & 7A)

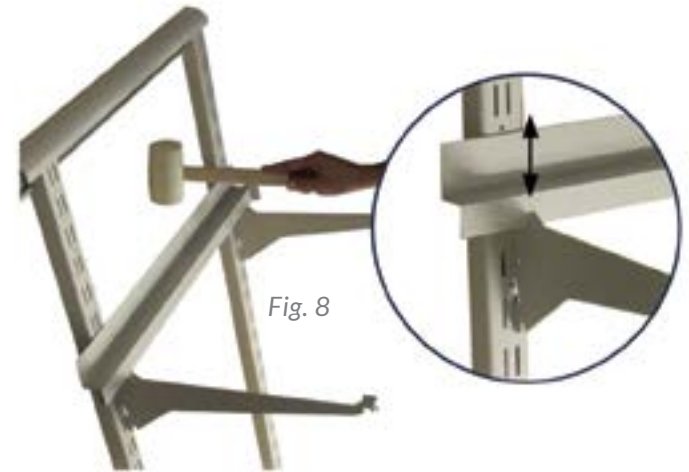

Fig. 8

Step 8 | Attach rear shelf rail. (Fig. 8)



Fig. 9

Step 9 | Attach front shelf rail. Take care not to damage powder coating.

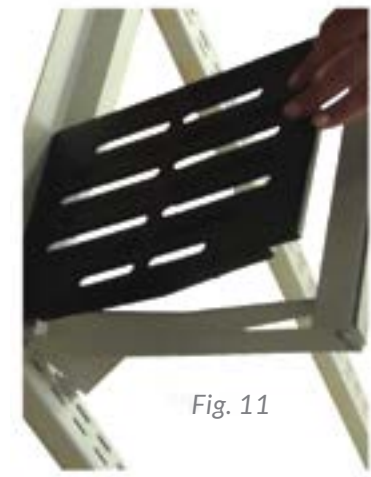

Fig. 11

Step 11 | Insert shelf panels. (Fig. 11)

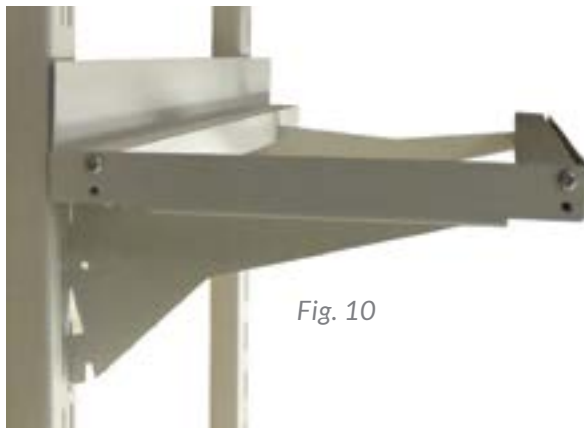

Fig. 10

Step 10 | Attach end stoppers/upstands. (Fig. 10)



Step 12 | Completed Unit.